

**AN AHP APPROACH TO THE ASSESSMENT OF THE COMPREHENSIVE
CAPABILITY OF THE MICROELECTRONIC SCIENCE AND TECHNOLOGY OF
CHINA IN COMPARISON WITH OTHER COUNTRIES'**

Fan Bingquan Qian Yanyun Gao Yubo

Shanghai Institute of Mechanical Engineering, China

ABSTRACT

An appropriate assessment of the comprehensive capability of microelectronic science and technology (ACCMST) in China will provide a necessary background for the formulating of the development strategy and policies of microelectronic technology (MT) in China. This is a multiple criteria problem. Usually, one of the critical issues in the multiple criteria problems is to determine the weights which are of comparative importance degrees among indices. Having delved further Saaty's AHP method, the authors give an improved algorithm and a comprehensive assessment matrix. Still, the authors made an international comparison of ACCMST among United States, China and Japan while combining these methods.

Introduction

There exists a big gap between China and other advanced countries in the microelectronics technology. It is a key point for us to formulate a proper development strategy and policy to improve the Chinese microelectronic industry. However, it is the basis of the formulation of the strategy and policy to make objectively assessment of the comprehensive capabilities of microelectronics science and technology of China and compare that with other countries'.

Indicator System of ACCMST

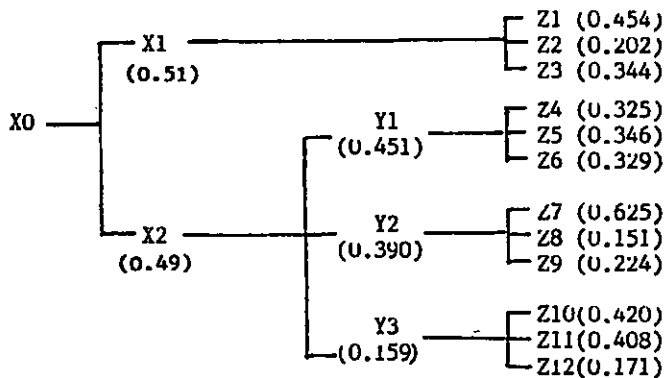

Figure 1. Indicator System of ACCMST

MT is a high technology, it has been widely and extensively applied in various fields. Thus it is possible to evaluate its comprehensive capabilities in different ways. The authors view that the science-technology system is closely correlated to the social economy. In order to assess the comprehensive capabilities of a nation or a district of MT, it is necessary that inputs, activities and outputs in MT should be taken into

consideration.

Figure 1. is a set of indicator system of ACCMST, which considers both international comparabilities and China's internal situations.

The meanings of indicators are:

- X0 — comprehensive capability assessment,
- X1 — potential of science and technology,
- X2 — capability of science and technology,
- Y1 — outcomes of science & technology,
- Y2 — technology capability,
- Y3 — production capability,
- Z1 — researchers; Z2 — R & D fund,
- Z3 — ratio of R & D fund to sales; Z4 — papers,
- Z5 — patents; Z6 — technology export,
- Z7 — technology trade; Z8 — IC export,
- Z9 — proportion of researchers to employees,
- Z10 — sales; Z11 — productivity,
- Z12 — capital expenditure.

A Comprehensive Assessment Matrix

(1) Element in The Matrix

It is a crucial problem to determine the weights of different indicators, i.e., indicator's relative importance in multiple criteria assessments, AHP has received popularities in recent years because of its simplicity and satisfactory results. The values of elements in the matrix are usual 1, 3, 5, 7, 9 or their reciprocal which represent indicators' relative importance suggested by Saaty. Of course, if necessary, one may use other values. No matter how to assign the values, it is impossible for those values to express the whole assessment information from questionnaires. Even being advised many times, experts may not reach a consensus. It is impossible, for instance, for all experts to think indicator *i* to be strongly more important than *j* or weakly important than *j*. Thus the element value synthesized the whole experts' suggestions in the matrix may not be the round numbers such as 1, 3, 5, 7, 9 or their reciprocal. If one fills in the matrix with such numbers, it does not represent the whole or true information. Some suggestions are proposed here.

(2) A Comprehensive Assessment Matrix

For simplicity, we take five scales 1, 3, 5, 7, 9. We use the shortened form to indicate the relative importance degree between two indicators.

- 1— equally important; 3— weakly important
- 5— strongly important; 7— demonstratedly important
- 9— absolutely important

and their reciprocal represents the important relationship to be inverse. First, suppose the assessment information after consulting with the experts two times is

	1	3	1/3	5	1/5	7	1/7	9	1/9
Index 1 to Index 2	$r_{1,2,1}$	$r_{1,2,3}$	$r_{1,2,9}$
⋮									
Index 1 to Index n	$r_{1,n,1}$	$r_{1,n,3}$	$r_{1,n,9}$
⋮									
Index n-1 to Index n	$r_{n-1,n,1}$	$r_{n-1,n,3}$	$r_{n-1,n,9}$

where r_{ijk} in the form indicates the number of experts who think the importance degree (indicator i to j) to be the rank k ($k=1, 3, 5, 7, 9, 1/3, 1/5, 1/7, 1/9$, total 9 degrees). Then suppose the returned tables number N . Because the experts' viewpoints are different, each degree may have some ones filling in when comparing indicator i with j , i.e.,

$$\sum_k r_{ijk} = N \quad (1)$$

where $k=1, 3, 5, 7, 9, 1/3, 1/5, 1/7, 1/9$.
Now, we synthesize the consulting information.

<1> . Importance Comparisons between Index 1 and 2, 3, ..., n

	1	3	1/3	5	1/5	7	1/7	9	1/9
Index 1. to index 2	$b_{1,1}$	$b_{1,3}$	$b_{1,9}$
⋮									
Index 1 to index n	$b_{1,n,1}$	$b_{1,n,3}$	$b_{1,n,9}$

where b_{ij} is the ratio of the expert number who think the importance degree (index 1 and index 2) in the same level to the total expert number, $b_{1,2}$ is the ratio of the expert number who think index 1 is absolutely more important than index 2 to the total experts; and so on. Therefore,

$$b_{1,2,1} = r_{1,2,1} / N \quad (2)$$

$$\sum_k b_{1,j,k} = 1 \quad (j=2,3, \dots, n)$$

<n-1> .. Importance Comparison between Index n-1 and n

	1	3	1/3	5	1/5	7	1/7	9	1/9
Index n-1 to index n	$b_{n-1,1}$	$b_{n-1,3}$	$b_{n-1,9}$

There are $n-1$ matrices of this kind. The i th matrix is the comprehensive one obtained by comparing the importance degree between index 1 and indices $i+1, i+2, \dots, n$. The first row is the row vector obtained by comparing the importance degree between index 1 and $i+1$, and so on.

In order to reflect the whole information about different grades in final assessment matrix, rightward multiplied the above $n-1$ matrices by $d^T = (d_1, d_2, d_3, d_5, d_7, d_9, d_{1/3}, d_{1/5}, d_{1/7}, d_{1/9})$, i.e.,

$$d^T = (1, 3, 1/3, 5, 1/5, 7, 1/7, 9, 1/9),$$

thus we get the assessment matrices which include the whole opinions of experts questioned.

Suppose the $n-1$ matrices above to be $B_1, B_2, B_3, \dots, B_{n-1}$, then

$$B_1^* = B_1 \cdot d^T = (C_{12}, C_{13}, \dots, C_{1n})$$

$$\vdots$$

$$B_{n-1}^* = B_{n-1} \cdot d^T = (C_{n-1,n})$$

by synthesizing these matrices, it is easy to obtain the final assessment matrix:

$$\begin{bmatrix} 1 & C_{12} & C_{13} & \dots & C_{1n} \\ & 1 & C_{23} & \dots & C_{2n} \\ & & & & \vdots \\ & & & & 1 \end{bmatrix}$$

From the above process, generally speaking, each element value in the matrix may not exactly be 1, 3, 5, 7, 9 or its reciprocal.

A Simple Method for Determining the Indicator's Weights

In multiple decisionmaking, Saaty has proposed a practical method known as AHP. However, AHP needs cumbersome calculations of the eigenvalue, eigenvector, and consistency test. Considering this point, we developed a more simple method which only needs the upper triangular matrix elements; this is as an attempt to improve Saaty's on this point. By using recursive procedure, we can easily get more satisfactory weight coefficients.

Let AHP matrix $T = [t_{ij}]$,

where
$$t_{ij} = \begin{cases} 1, & i = j, \\ t_{ij} = 1/t_{ji} > 0, & i \neq j. \end{cases}$$

We are much interested in its upper triangular part. Define its upper triangular matrix $A = [a_{ij}]$;

where

$$a_{ij} = \begin{cases} t_{ij}, & j \geq i, \\ 0, & \text{otherwise.} \end{cases}$$

Here, a_{ij} is the relative importance ratio of index i to j decided by experts. In fact, a_{ij} is an estimate ratio of weights W_i to W_j , i.e., $a_{ij} = W_i/W_j = \hat{W}_i/\hat{W}_j$. We could use W_i and W_j instead of \hat{W}_i and \hat{W}_j in the following discussion without confusion. Thus, $a_{ij} = W_i/W_j$. Usually, the estimation does not meet the consistency constraint, i.e., $a_{ij} \neq a_{ik} \cdot a_{kj}$. Now the upper triangular matrix A is

$$\begin{pmatrix} a_{11} & a_{12} & \dots & a_{1n} \\ & a_{22} & \dots & a_{2n} \\ & & & \vdots \\ & & & a_{nn} \end{pmatrix} \quad a_{ii} = 1$$

Then, by observing the second column elements of A , there is only one element which is a_{12} (excluding diagonal element, and this condition holds true in the following discussions), thus

$$W_1 = a_{12} \cdot W_2 \quad (3)$$

and by observing column three, there are two elements, a_{13} and a_{23} . If consistency holds, we have

$$W1 = a13 * W3, \quad (4)$$

and
$$W2 = a23 * W3 \quad (5)$$

Actually, the intuitive judgement of the experts does not meet the consistency requirement. In order to relieve this constraint, adding equation (4) to (5),

$$W1 + W2 = (a13 + a23) * W3 \quad (6)$$

by the same token, column four will be

$$W1 + W2 + W3 = (a14 + a24 + a34) * W4.$$

column n-1,

$$W1 + W2 + \dots + W_{n-1} = (a_{1,n-1} + a_{2,n-1} + \dots + a_{n-1,n-1}) * W_{n-1} \quad (7)$$

column n,

$$W1 + W2 + \dots + W_n = (a_{1,n} + a_{2,n} + \dots + a_{n,n}) * W_n \quad (8)$$

in addition, there is still a normalization constraint

$$W1 + W2 + \dots + W_n = 1 \quad (9)$$

now, combining the above equations into matrix form, i.e.,

$$\begin{pmatrix} 1 & -a_{12} & 0 & \dots & 0 & 0 \\ 1 & 1 & -a_{23} - a_{33} & \dots & 0 & 0 \\ \vdots & \vdots & \vdots & \ddots & \vdots & \vdots \\ 1 & 1 & \dots & \dots & 1 - \sum_{k=1}^{n-1} a_{kn} & 0 \\ 1 & 1 & \dots & \dots & 1 & 1 \end{pmatrix} \begin{pmatrix} W_1 \\ W_2 \\ \vdots \\ W_{n-1} \\ W_n \end{pmatrix} = \begin{pmatrix} 0 \\ 0 \\ \vdots \\ 0 \\ 1 \end{pmatrix} \quad (10)$$

In real situations, each weight should be greater than zero. This requires that the above left square matrix (let it be S) is not singular in a physical sense.

Theorem 1. There is a unique solution to (10), with strictly positive components.

Proof, first, starting with row n-1 in S, obviously, the two sides meet

$$W1 + W2 + \dots + W_{n-1} - (a_{1,n-1} + a_{2,n-1} + \dots + a_{n-1,n-1}) * W_{n-1} = 0$$

or
$$(a_{1,n-1} + a_{2,n-1} + \dots + a_{n-1,n-1}) * W_{n-1} = W1 + W2 + \dots + W_{n-1}$$

adding W_n to both sides, then the right side is 1, and

$$(a_{1,n-1} + a_{2,n-1} + \dots + a_{n-1,n-1}) * W_{n-1} + W_n = 1$$

$$W_n = 1 / (1 + a_{1,n-1} + a_{2,n-1} + \dots + a_{n-1,n-1}) \quad (11)$$

thus W_n is obtained. Note that the denominator in the above equation equal to the sum of column n elements in A , including diagonal element. Then observe row $n-2$ in S , the both sides satisfy

$$W_1 + W_2 + \dots + W_{n-2} = \left(\sum_{i=1}^{n-2} a_{i,n-1} \right) * W_{n-1}$$

adding W_n to both sides, thus

$$\begin{aligned} 1 - W_n &= \sum_{i=1}^{n-2} W_i + W_{n-1} = \left(\sum_{i=1}^{n-2} a_{i,n-1} \right) * W_{n-1} + W_{n-1} \\ W_{n-1} &= (1 - W_n) / \left(1 + \sum_{i=1}^{n-2} a_{i,n-1} \right) \end{aligned} \quad (12)$$

therefore, we can get W_n and consequently, W_n can be obtained. We'd still pay much attention to the above denominator, which is equal to the sum of column $n-1$ elements in A .

By examining the forms of W_n and W_{n-1} , some regular terms can be noticed, i.e., the denominator term is the sum of column n elements in A by solving W_n , and the correspondent term is the sum of column $n-1$ by solving W_{n-1} , and the nominator equals unity minus W_n . Based on these, we can obtain the recursion formula of W_i . Suppose W_1, W_2, \dots, W_n have been solved, and W_i 's form is

$$W_i = \left(1 - \sum_{k=i+1}^n W_k \right) / \left(1 + \sum_{k=i}^{i-1} a_{k,i} \right) \quad (13)$$

where the denominator is also the sum of column i in A . Now solving W_{i-1} . Observing row $i-2$ in S , the two sides have

$$W_1 + W_2 + \dots + W_{i-2} = (a_{1,i-1} + a_{2,i-1} + \dots + a_{i-2,i-1}) * W_{i-1}$$

adding W_{i-1} to both sides, then

$$1 - \sum_{k=i}^n W_k = \left(\sum_{k=i}^{i-2} a_{k,i-1} + 1 \right) * W_{i-1}$$

i.e.,

$$W_{i-1} = \left(1 - \sum_{k=i}^n W_k \right) / (1 + a_{1,i-1} + a_{2,i-1} + \dots + a_{i-2,i-1}) \quad (14)$$

Its denominator is also the sum of column $(i-1)$ in A . So the hypothesis holds true. Note that there is exactly one solution, with all $W_i > 0$, such that $W_1 + W_2 + \dots + W_n = 1$. Refer to [Gao, et al] for detailed discussions about Saaty's vector weight and our's.

While applying this method to solving real problems, the procedure is just the same as the proof process: start with W_n , and gradually progress toward W_1 . In vector form, the W can be expressed as

$$W = S^{-1} * e \quad (15)$$

where $e = (0, 0, \dots, 0, 1)$

Example 1. Now we use our studies of ACCMST to illustrate the weights solving procedures. Having questioned experts, referring to indicator set before, we know the importance relationships between indicators 1, 2, and 3. Their matrix form is

$$\begin{pmatrix} 1 & 2.25 & 1.32 \\ & 1 & 0.59 \\ & & 1 \end{pmatrix}$$

applying the procedure above. It is easy to calculate weights W_1 , W_2 , and W_3 .

$$W_3 = 1 / (1 + 1.32 + 0.59) = 0.344$$

$$W_2 = (1 - W_3) / (1 + 2.25) = 0.202$$

$$W_1 = 1 - W_2 - W_3 = 0.454$$

It is worth to mention that the method we have proposed above is easier than that of Saaty's. Moreover, the proof by recursion or Theorem 1 reveals an iterative solution method which can be done by hand.

ACCST among China, Japan, and United States

Based on the studies of many multiple criteria assessment models, taking into accounts of microelectronics characteristics, we present a model as follows.

$$U = 1 - \prod_i (1 - W_i * U_i) \quad (16)$$

where U --- comprehensive assessment value of one country

U_i --- the value of indicator i

W_i --- the weight of indicator i

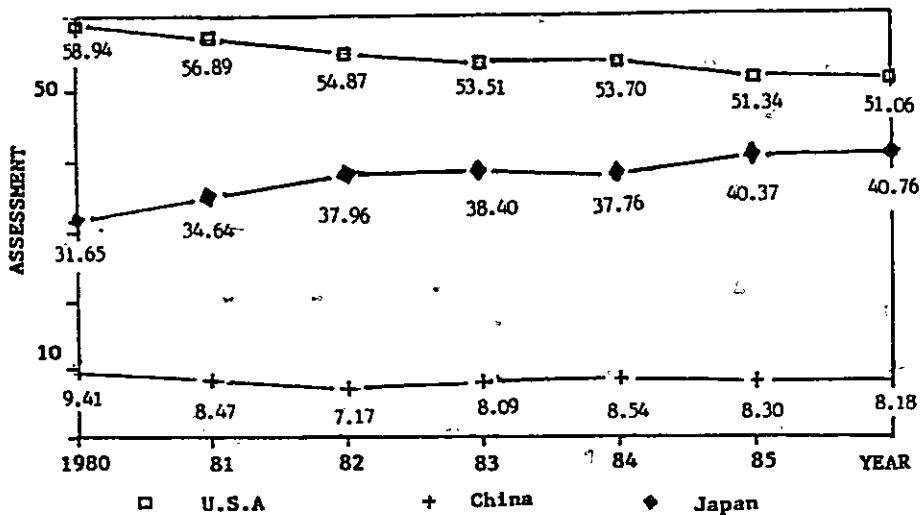

Figure 2. Comprehensive Assessment among China, Japan, and U.S.A.

Table 1 COMPREHENSIVE ASSESSMENTS
(80-86)

YEAR	1980	1981	1982	1983	1984	1985	1986
U.S.A.	58.94	56.89	54.87	53.51	53.70	51.34	51.06
CHINA	9.41	8.47	7.17	8.09	8.54	8.30	8.18
JAPAN	31.65	34.64	37.96	38.40	37.76	40.37	40.76

By using the weights calculated by the method above, related data of United States and Japan during 1980--1986, as well as the data in Chinese investigation in 1986, and the model, we made an international assessment of MT. The results are listed in Table 1 and Figure 2.

Our research shows that there is a some difference between U.S.A. and Japan, in spite of Japan has made much efforts in MT. However, this difference is becoming smaller, and this tendency is speeding up now. There is a great difference between China and U.S.A., as well as Japan. The difference is overall and fundamental. As we believe, it is possible that this gap could be narrowed, but, it needs reasonable development strategies, appropriate policies, and hard efforts for a long time.

REFERENCES

- Cogger, K.O and Yu, P.L., Eigenweight Vectors and Least Distance Approximation for Revealed Preference in Pairwise Weight Ratios, Journal of Optimization theory and Application, Vol.46, No4, August, 1985.
- E.Takeda, K.O. Cogger and P. L., Yu, Estimating Criterion Weights Using Eigenvectors: A Comparative Study, European Journal of Operational Research, vol.29. pp.360-369, 1987, North-Holland.
- Saaty, T.L., Decisionmaking, New Information, Ranking And Structure, 5th ICNM, 1985, California, U.S.A.
- Liu Bao, et al. AHP--Tool of Programming Decisionmaking, System Engineering, Vol.2, No.2, 1984. (in Chinese).
- Gao Yubo, Fan Bingquan and Qian yanyun, A Simple Method for Determining Weights, Working Paper, Shanghai Institute of Mechanical Engineering, May, 1980.